

REV A	DATE 09APR2002	DRAWN/CHKD GDM	DESCRIPTION UPDATE FORMAT		No. 82 CLIP-ON RECEPTACLE	DATE 20DEC93	DRAWN ALC	CHKD ACZ	SCALE NTS	DRAWING NUMBER TD-82-15-J

SOUTHCO PERFORMANCE GUIDELINES
 THE PERFORMANCE GUIDELINES SHOWN ON THIS PAGE ARE SUPPLIED AS A GENERAL GUIDE ONLY, AS CONDITIONS VARY WITH EACH APPLICATION AND METHOD OF INSTALLATION. STRENGTH DATA GIVEN IS FOR FAILURE OF THE PRODUCT OR FOR SUFFICIENT DEFORMATION TO MAKE PRODUCT INOPERABLE. NO SAFETY FACTOR HAS BEEN APPLIED. IT IS RECOMMENDED THAT THE USER REQUEST A PRODUCT SAMPLE FOR TESTING TO DETERMINE THE SUITABILITY OF THE PRODUCT FOR THE PURPOSE INTENDED AND USER'S PARTICULAR APPLICATION.

ALL STRENGTH RATINGS ARE INDEPENDENT OF HEAD STYLE.

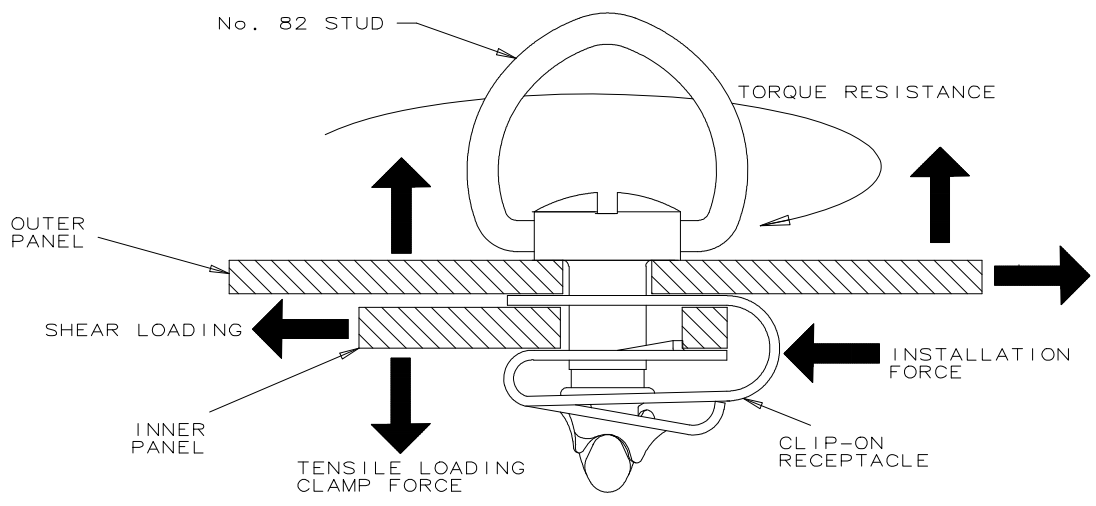

PART NUMBER	82-47-113-15	82-47-113-20
MAXIMUM RECOMMENDED WORKING TENSILE STRENGTH ①	900 N (200 LBS)	550 N (125 LBS)
AVERAGE ULTIMATE TENSILE STRENGTH ②	2700 N (600 LBS)	2445 N (550 LBS)
CLAMP FORCE ③	90 N (20 LBS)	90 N (20 LBS)
MAXIMUM RECOMMENDED WORKING SHEAR STRENGTH ①	900 N (200 LBS)	900 N (200 LBS)
AVERAGE ULTIMATE SHEAR STRENGTH ②	2000 N (450 LBS)	2000 N (450 LBS)
MAXIMUM TORQUE RESISTANCE ④	2.4 Nm (21 IN-LBS)	2.2 Nm (19 IN-LBS)
INSTALLATION FORCE ⑤	110 N (25 LBS)	110 N (25 LBS)

- ① WORKING LOAD is the maximum force that the product will withstand without affecting the operation or appearance of the product.
- ② Average ULTIMATE LOAD causes failure of the product or sufficient deformation to make the product inoperable.
- ③ CLAMP FORCE is the force applied to the panel when the assembly is latched at the nominal grip.
- ④ MAXIMUM TORQUE RESISTANCE is the torque that causes the stud to override the receptacle stop.
- ⑤ INSTALLATION FORCE is the force required to install the receptacle in to the minimum frame thickness. (tested in 1008 - 1010 steel)



PROPRIETARY ITEM - EXCEPT FOR USES EXPRESSLY GRANTED IN WRITING, INFORMATION DISCLOSED HEREON IS CONFIDENTIAL AND ALL RIGHTS, PATENT AND OTHERWISE ARE RESERVED BY SOUTHCO, INC.